

R106 Electric

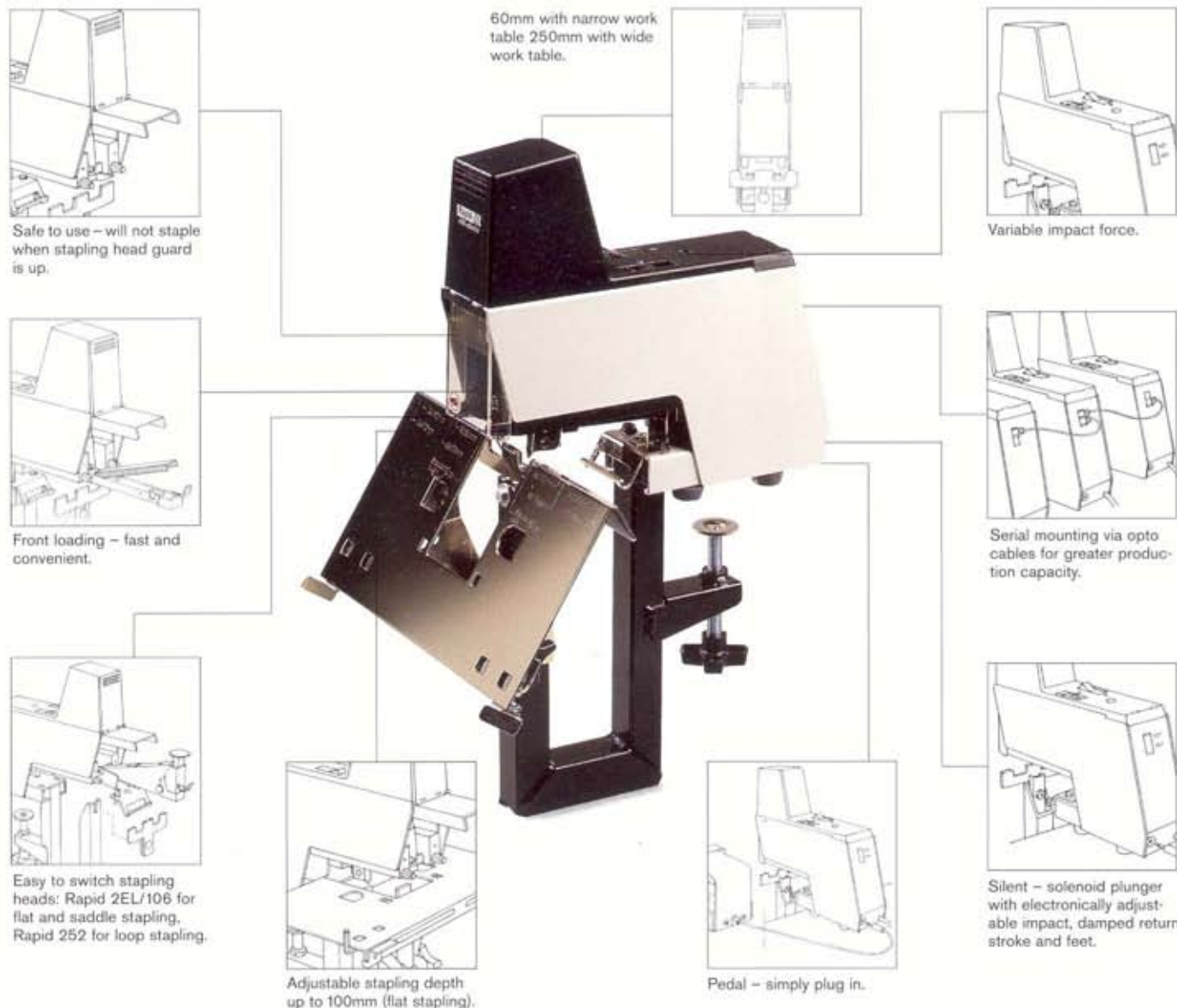

Professional precision

THE R106E IS SIMILAR TO THE R105E, BUT INCLUDES A WORK TABLE FOR FLAT AND SADDLE STAPLING.

It can staple brochures or folders, with the work table folded down, as speedily and easily as it staples loose sheets or stacks of paper in the flat position. And it can be fitted with an insert stapler for loop staples (optional extra).

All Rapid products are subjected to comprehensive quality controls, from stringent component tests and exacting performance tests to very rigorous life-cycle tests. These quality control procedures are carried out both prior to manufacture (as part of all design and development work) and during manufacture (as continual product audits). We are, of course, certificated in accordance with the ISO 9001 quality management system and the ISO 14 000 environmental management system.

Narrow work table (60mm) with anvil. (Optional extra).



Rapid 252/106 stapling head for loop stapling. (Optional extra).

Special rail for saddle stapling with one or more R106E staplers. (Optional extra).



Simultaneous stapling action via linked opto cables (40 or 70cm). The staplers are sequence controlled, to avoid overloading the power supply. (Optional extra).