

## IDEAL 7260





- D** Bitte lesen Sie vor Inbetriebnahme der Maschine unbedingt diese Betriebsanleitung und beachten Sie die Sicherheitshinweise. Die Betriebsanleitung muss jederzeit verfügbar sein.
- GB** Please read these operating instructions before putting the machine into operation and observe the safety precautions. The operating instructions must always be available.
- F** Nous vous prions de lire attentivement le mode d'emploi avant d'utiliser la machine, et attirons votre attention sur les consignes de sécurité. Les instructions d'utilisation et les consignes de sécurité doivent toujours être disponibles. Les instructions d'utilisation et les consi.
- NL** Leest u voor de ingebruik name van het apparaat a.u.b. deze gebruiksaanwijzing goed door en neemt u de veiligheidsinstructies n acht. De gebruiksaanwijzing en de veiligheids-voorschriften moeten altijd binnen handbereik zijn.
- I** Per favore legga questo manuale di istruzione prima di mettere in funzione il distruggidocumenti e osservi le regole di sicurezza. Le istruzioni d'uso devono essere sempre disponibili.
- E** Le recomendamos lea las instrucciones antes de poner en funcionamiento esta máquina y cumpla las normas de seguridad. Las instrucciones de servicio y seguridad deben estar siempre disponibles.
- S** Läs igenom denna bruksanvisning innan ni startar maskinen. Var noga med säkerhetsföreskrifterna. Instruktionsmanualen måste alltid finnas tillgänglig.
- FIN** Lue nämä käyttö-ohjeet läpi ennenkuin käynnistät laitteen !  
Noudata turvaohjeita. Käyttöohjeiden on oltava aina saatavilla.
- N** Lees gjennom denne bruksanvisningen før De tar i bruk maskinen  
Vær oppmerksom på sikkerhetsforskriftene. Operatørmmanualen må alltid være tilgjengelig.
- PL** Proszę uważnie przeczytać instrukcję obsługi przed uruchomieniem urządzenia i stosować się do przepisów bezpieczeństwa. Instrukcje obsługi muszą być zawsze dostępne.
- RUS** Пожалуйста, прочитайте инструкцию по эксплуатации перед установкой аппарата, соблюдайте технику безопасности. Инструкция по эксплуатации должна находиться в доступном для пользователя месте.
- H** A gép üzembe helyezésé előtt figyelmesen olvassa el a kezelési utasítást és tartsa be a biztonságí előírásokat. A kezelési utasításnak mindig elérhetőnek kell lennie.
- TR** Lütfen makineyi çalıştırmadan önce bu kullanma talimatlarını dikkatli bir şekilde okuyunuz ve belirtilen güvenlik önlemlerine uyunuz. Kullanma Talimatları her zaman kullanıma hazır olmalıdır.
- DK** Før installation af maskinen bedes De venligst læse brugervejledningen og være opmærksom på sikkerhedsanvisningerne. Brugervejledningen skal altid være tilgængelig.
- CZ** Prosim přečtete si instrukce k obsluze a dodržujte bezpečnostní upozornění. Návod k obsluze musí být vždy dostupný.
- P** Por favor leiam o manual de instruções antes de colocar a máquina em operação e vejam as precauções de segurança. As instruções de operação deverão estar sempre disponíveis.
- GR** ΠΑΡΑΚΑΛΩ ΔΙΑΒΑΣΤΕ ΤΙΣ ΟΔΗΓΙΕΣ ΧΡΗΣΕΩΣ ΚΑΙ ΤΙΣ ΠΡΟΦΥΛΑΞΕΙΣ ΑΣΦΑΛΕΙΑΣ ΠΡΙΝ ΒΑΛΕΤΕ ΤΟ ΜΗΧΑΝΗΜΑ ΣΕ ΛΕΙΤΟΥΡΓΙΑ. ΟΙ ΟΔΗΓΙΕΣ ΧΡΗΣΗΣ ΠΡΕΠΕΙ ΝΑ ΕΙΝΑΙ ΠΑΝΤΑ ΔΙΑΘΕΣΙΜΕΣ.
- SLO** Prosimo preberite navodila za uporabo ter upoštevajte varnostna opozorila preden zaženete napravo. Navodila naj bodo vedno pri roki.
- SK** Starostlivo si preštudujte tento návod na obsluhu pred uvedením stroja do prevádzky a najmä bezpečnostné predpisy. Držte tento návod na obsluhu na dostupnom mieste.
- EST** Palun lugege enne masina käivitamist käesolevat kasutusjuhendit ning järgige ohutusnõudeid. Kasutusjuhend peab alati käepärast olema.
- CHI** 使用機器前，請閱讀此操作指引，並留意安全守則  
操作手册必须是经常可用的。
- UAE** والامان الوقاية تعليمات ملاحظة نرجوا كما الماكينة بتشغيل البدء قبل التشغيل تعليمات قراءة نرجوا لا بد من وجود تعليمات التشغيل دائما



- D** Keine Bedienung durch Kinder!  
**GB** Children must not operate the machine!  
**F** Pas d'utilisation par un enfant!  
**NL** Geen bediening door kinderen!  
**I** Non lasciare utilizzare il tagliacarte a bambini!  
**E** No dejar que la utilicen los niños!  
**S** Installera maskinen utom räckhåll för barn!  
**FIN** Asentakaa laite lasten ulottumattomiin !  
**N** Installer maskinen utenfor rekkevidde for barn!  
**PL** Dzieciom nie wolno obsługiwać urządzenia !  
**RUS** Не допускайте детей к пользованию аппаратом!  
**H** Gyerekek a gépet nem kezelhetik  
**TR** Makinayı Çocuklar Kullanmamalıdır.  
**DK** Må kun betjenes af voksne  
**CZ** Stroj nesmí být obsluhován dětmi!  
**P** As crianças não devem trabalhar com a máquina!  
**GR** ΑΠΑΓΟΡΕΥΕΤΑΙ Η ΧΡΗΣΗ ΑΠΟ ΠΑΙΔΙΑ.  
**SLO** Otroci ne smejo uporabljati naprave  
**SK** So strojom nesmú pracovať deti!  
**EST** Lapsed ei tohi masinat kasutada!  
**CHI** 勿让儿童使用机器!  
**UAE** يجب علي الأطفال عدم تشغيل الماكينة.



- D** Nicht unter das Messer fassen!  
**GB** Do not reach beneath the blade!  
**F** Ne pas passer les mains sous la lame!  
**NL** Niet met de handen onder het mes komen!  
**I** Non toccare la lama nella parte inferiore!  
**E** ¡No tocar debajo de la cuchilla!  
**S** Sträck inte in handen under kniven!  
**FIN** Älä laita kättäsi terän alle !  
**N** Plasser aldri hender ol. under kniven !  
**PL** Nie wkładać rąk pod noże!  
**RUS** Избегайте попадания рук под лезвие!  
**H** Ne nyúljon a kés alá!  
**TR** Elinizi bıçağın altına sokmayınız!  
**DK** Stik ikke hænderne ind under knivbladet!  
**CZ** Nesahejte pod ostří nože!  
**P** Não tocar na parte inferior da faca!  
**GR** ΜΗΝ ΑΓΓΙΖΕΤΕ ΤΟ ΚΑΤΩ ΜΕΡΟΣ ΤΗΣ ΛΕΠΙΔΑΣ!  
**SLO** Ne segajte z roko pod rezilo!  
**SK** Nevkladajte ruky pod nôž!  
**EST** Ärge pange kätt tera alla!  
**CHI** 请勿接触刀具的下方。  
**UAE** لا تصل تحت السكين





- D** Messer nie lose liegen lassen!  
Messer nur mit Messerwechsellvorrichtung oder im  
Messertransportkasten befördern!  
(siehe Seite 29 und 31).  
⚠ **Warnung! Verletzungsgefahr!**
- GB** Never leave the blade unattended!  
Do not extract or transport the blade without protection!  
(See page 29 and 31).  
⚠ **Danger! Risk of injury!**
- F** Ne jamais laisser la lame sans protections !  
Elle ne doit être démontée qu'à l' aide du dispositif de  
changement de lame (cf. page 29 et 31), ou transportée dans  
son étui en bois !  
⚠ **Danger ! Risques de coupures !**
- NL** Laat nooit de messen alleen achter.  
Transporteer de messen niet zonder de houten bescherming  
(zie pagina 29 en 31).  
⚠ **Waarschuwing! Opgelet voor ongevallen!**
- I** Non lasciare mai la lama incustodita. Non rimuovere o  
trasportare la lama senza protezione. (Vedi pagina 29 e 31).  
⚠ **Attenzione! Rischio di infortunio!**
- E** ¡No quitar la cuchilla sin prestar atención. No desmontar no  
transportar la cuchilla sin protección! (vérase pág. 29 y 31)  
⚠ **¡Advertencia! ¡Peligro de hacerse daño!**
- S** Lämna aldrig maskinen obemannad. Ta inte ur eller  
transportera kniven utan skydd. (se sid 29 och 31).  
⚠ **Skaderisk!**
- FIN** Käsittele terää aina varoen. Älä siirrä tai kuljeta  
terää ilman suojaa ! (katso sivu 29 ja 31)  
⚠ **Loukkaantumisen vaara !**
- N** La aldri kniven ligge ubeskyttet. Ta aldri ut kniven eller  
transporter den uten beskyttelse (Se side 29 og 31)  
⚠ **FARE ! Muligheter for skade !**
- PL** Nigdy nie pozostawiać noży bez nadzoru.  
Nie wyciągać lub transportować noży bez osłon!  
(zobacz strona 29 i 31).  
⚠ **Ryzyko skaleczenia sie!**
- RUS** Не оставляйте открытое лезвие без присмотра! Не  
пытайтесь извлечь или транспортировать лезвие без  
специальных мер предосторожности!  
(См. страницы 29 и 31)  
⚠ **Соблюдайте выше перечисленные правила  
для избежания травм!**
- H** Soha ne hagyja a kést őrizetlenül!  
Ne vegye ki vagy ne szállítsa a kést védőtok nélkül!  
(Lásd 29. és 31. oldal)  
⚠ **Veszély! Sérülésveszély!**
- TR** Bıçağı hiçbir zaman gözetimsiz bırakmayınız!  
Bıçağı muhafazasız olarak yerinden çıkartmayınız veya  
taşımayınız! (Sayfa 29 ve 31'e bakınız)  
⚠ **Dikkat! Yaralanma riski!**



- DK** Knivbladet må aldrig efterlades uden opsyn.  
Forsøg ikke at afmontere eller transportere knivbladet uden beskyttelse! (Se side 29 og 31)  
⚠ **FARE! Risiko for legemlig beskadigelse.**
- CZ** Nikdy nenechávejte nůž bez krytu.  
Nikdy nevyjímejte nebo neprepravujte nůž bez ochranného krytu (viz. strany 29 a 31)  
⚠ **Nebezpečí! Riskujete zranění**
- P** Deixar a faca sempre em local seguro!  
Não retirar ou transportar a faca sem protecção!  
(Ver pág. 29 e 31)  
⚠ **Perigo! Risco de dano!**
- GR** ΜΗΝ ΑΦΗΝΕΤΕ ΤΗΝ ΛΕΠΙΔΑ ΑΝΕΠΙΤΗΡΗΤΗ!  
ΜΗΝ ΑΛΛΑΖΕΤΕ Ή ΜΕΤΑΦΕΡΕΤΕ ΤΗΝ ΛΕΠΙΔΑ ΧΩΡΙΣ ΠΡΟΦΥΛΑΞΗ (Δείτε σχετικά στις σελίδες 29 & 31)  
⚠ **ΠΡΟΣΟΧΗ ! ΚΙΝΔΥΝΟΣ ΤΡΑΥΜΑΤΙΣΜΟΥ !**
- SLO** Nikoli ne puščajte rezila nazaščitenega. Nikoli ne prenašajte rezilo brez zaščite. (glej stran 29 in 31).  
⚠ **Pozor! Nevarnost poškodbe.**
- SK** Nenechávajte nôž nechránený (nezabezpečený)!  
Nevyberajte alebo netransportujte nôž bez ochrany  
(vid s. 29 a 31)  
⚠ **! Riziko ťrazu !**
- EST** Ärge jätke lõiketera kunagi järelevalveta!  
Ärge pikendage ega teisaldage tera kaitseseadmeteta!  
(Vt lk 29 ja 31.)  
⚠ **Oht! Vigastuste oht!**
- CHI** 在没人留意的情况下，请勿离开刀具。  
在没有保护的情况下，请勿取出或运送刀具！（参阅第 29 和 31 页）。  
⚠ 危险！可引致受伤！
- UAE** لا تترك السكين بدون اهتمام  
لا تخرج أو تنقل السكين بدون حماية (أنظر صفحة 29 و 31)  
⚠ خطر! التعرض للآذى

IDEAL 7260

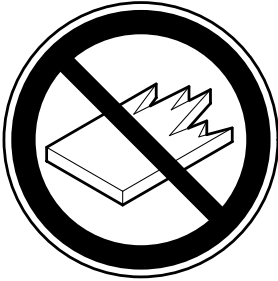

- D** Keine harten und splitternden Materialien schneiden!
- GB** Do not cut hard materials or materials which may splinter!
- F** La coupe de matériaux trop durs ou risquant des projections est interdite !
- NL** Snij geen harde materialen of materiaal dat kan splinteren!
- I** Utilizzare il tagliacarte esclusivamente per il taglio di risme di carta o materiali analoghi!
- E** ¡No cortar materiales duros o materiales que puedan astillarse!
- S** Försör inte hårt material eller material som kan splittras!
- FIN** Asentakaa laite lasten ulottumattomiin !
- N** Ikke kutt hardt metall eller materiale som kan splintre !
- PL** Nie ciąć twardych materiałów lub materiałów, które mogą ulec odprysnięciu!
- RUS** Данный резак не предназначен для резки твердых материалов или материалов, которые могут расщепляться!
- H** Ne vágjon kemény vagy olyan anyagot, amely repedhet!
- TR** Sert veya parçalanabilecek malzemeleri kesmeyiniz!
- DK** Der må ikke skæres i hårde materialer eller i materialer, der kan splintre!
- CZ** Neřežte tvrdý materiál, při kterém mohou ustřelovat ostré úlomky!
- P** Não cortar materiais duros ou materiais que possam lascar!
- GR** ΜΗΝ ΚΟΒΕΤΕ ΣΚΛΗΡΑ ΥΛΙΚΑ Ή ΥΛΙΚΑ ΠΟΥ ΘΡΥΜΜΑΤΙΖΟΝΤΑΙ!
- SLO** Nikoli ne režite trdih materialov ali materialov, ki se lahko razcepijo.
- SK** Nerežte tvrdé materiály, alebo materiály, z ktorých môžu vystrelovať ostré úlomky
- EST** Ärge lõigake kõvasid materjale ega materjale, mis võivad pilbasteks puruneda!
- CHI** 请勿切割坚硬或可裂成碎片物料。
- UAE** لا تقطع الأشياء الصلبة أو الأشياء التي يتطاير منها شظايا!

• Safety precautions •

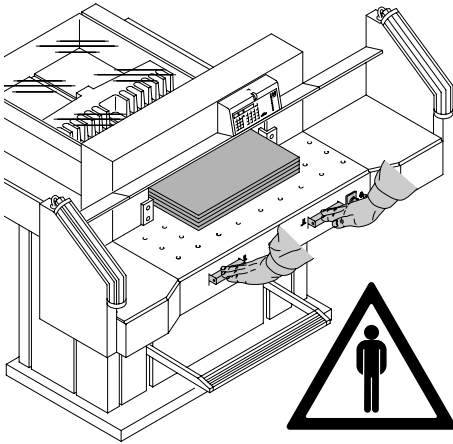

The machine is designed for cutting stacks of paper to a specified size. This machine is constructed for "one-man operation" only!  
⚠ **Warning!** Clips or similar damage the cutting blade.

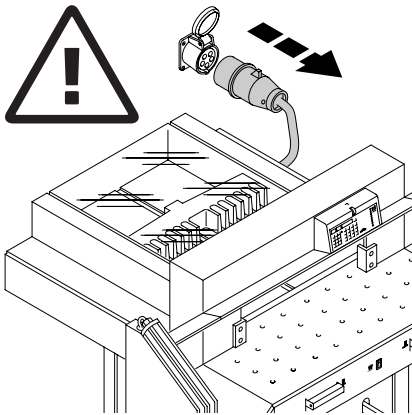

Disconnect from the mains before starting any service work or before removing the panels!

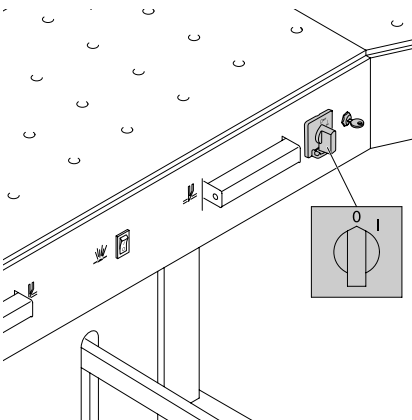

Replacement of blade and cutting stick may be performed only when the main switch is switched off!

IDEAL 7260

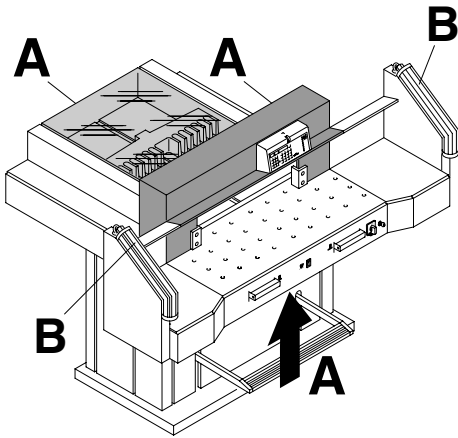

All components which may endanger the operator are covered by a guard (A).

Do not operate the machine without the following safety devices:

- Panels, tightly screwed (A).
- Safety beam guard (B).

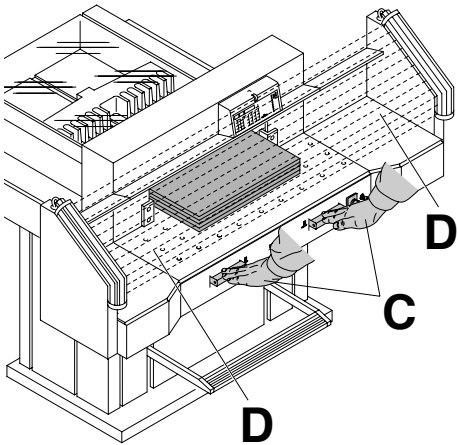

The cutting action, which is dangerous to the operator, is protected by a two-handed control system (C) and safety beam guard (D).



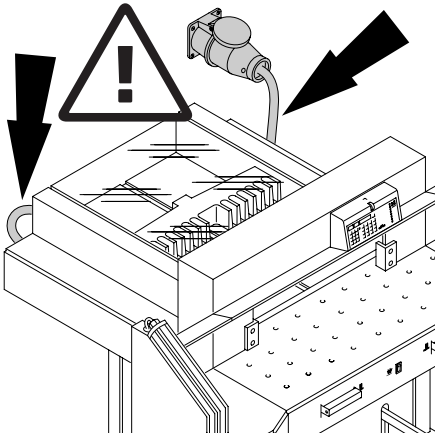

Protect mains cable against heat, oil and sharp edges!

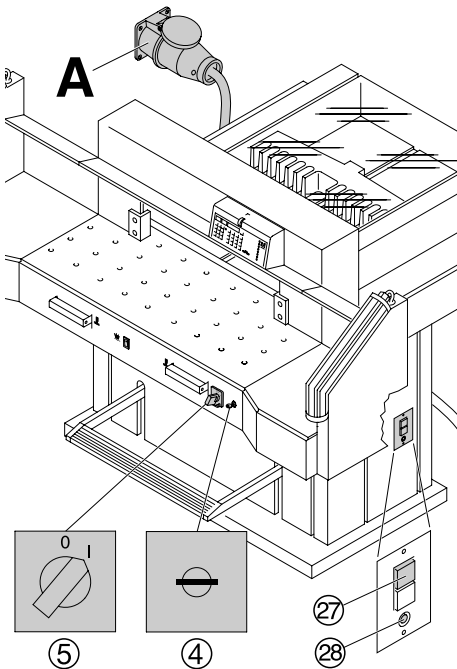

Standard machines are factory-set as follows:

- Voltage 400 V (220 V) 3 phase
- Frequency 50 Hz (60 Hz).

### Machine does not function

- Is the machine ⑤ switched on?
- Is the key-switch ④ on.
- Is the green overload switch ⑲ pressed?
- Is the black overload switch ⑳ pressed?
- Check on-site fuse.

If the machine still does not function then the rotation must be reversed.

The machine is wired according to the IEC standards. We recommend that alterations to the rotary direction be made in the socket. It is also possible to make alterations in the plug by exchanging "L1" and "L2".

### ⚠ Danger!

Incorrect exchanging of the connections will endanger the operator.

**This work must be carried out by an electrician.**

IDEAL 7260

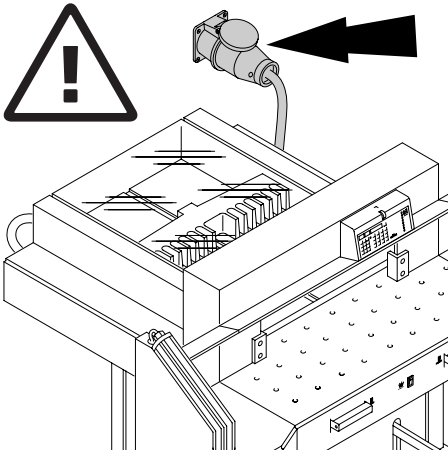

Ensure free access to mains!

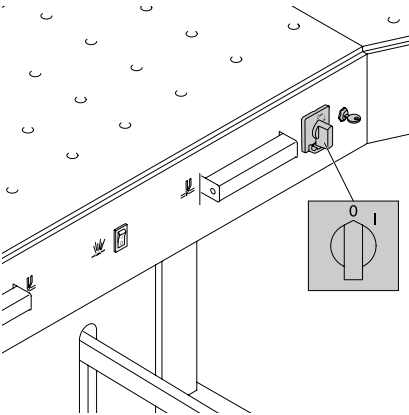

When not in use for a longer period switch off.  
(Main switch to "0").

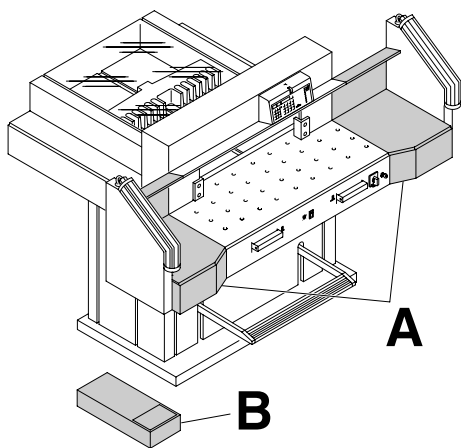

The machine is delivered ready for operation. 6 strong people are required to lift the machine from the pallet.

Side tables, left and right, (A) are available as accessories.

Attach the side tables to the front table so that the upper surface is level. (Screws and nuts are in a plastic bag in the tool set (B)).

**Reassemble the safety light beam.**

For transport through narrow doors:

- Remove side tables

**⚠ Danger!**

**The machine must not be put into operation without the safety light beam.**

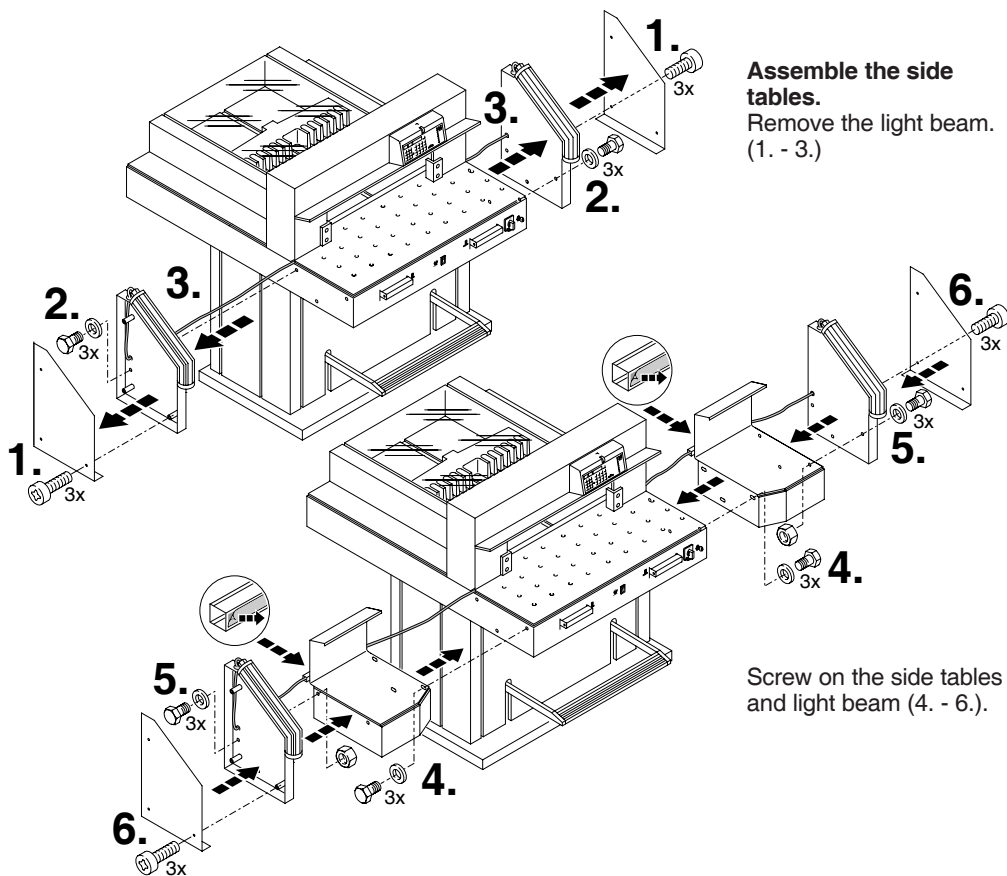

**Assemble the side tables.**  
Remove the light beam.  
(1. - 3.)

**Screw on the side tables and light beam (4. - 6.).**

IDEAL 7260

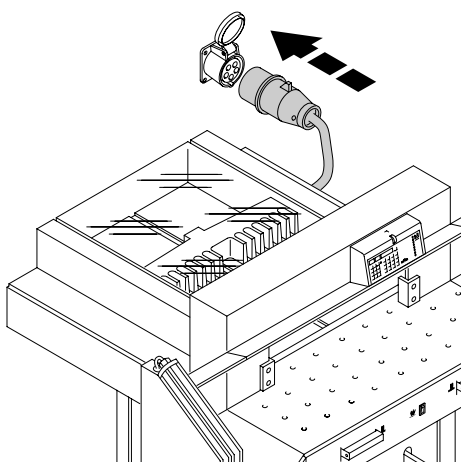

Plug into socket.

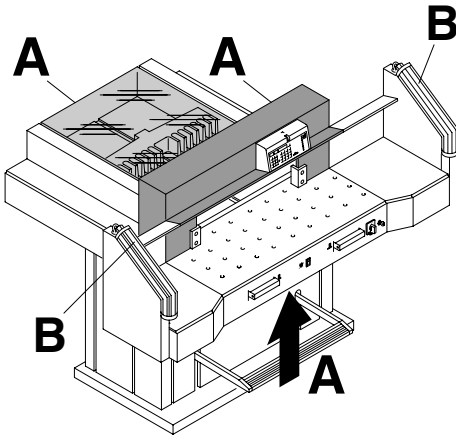

It is forbidden to operate the machine if the operating and safety instructions have not been understood. Please check the safety devices are functioning and complete before use.

- All covers have to be mounted (A).
- Safety beam guard must be mounted (B).
- The release for cutting is allowed only if the two-hand safety device is operated at the same time (C)
- **Safety light beam:**  
**The machine stops immediately if anyone reaches into the cutting area (D).**

We recommend you keep a record of your test results.

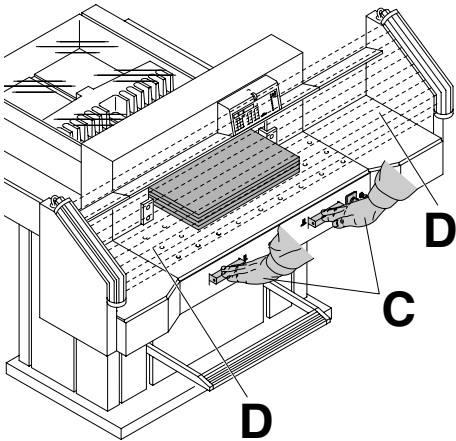

IDEAL 7260

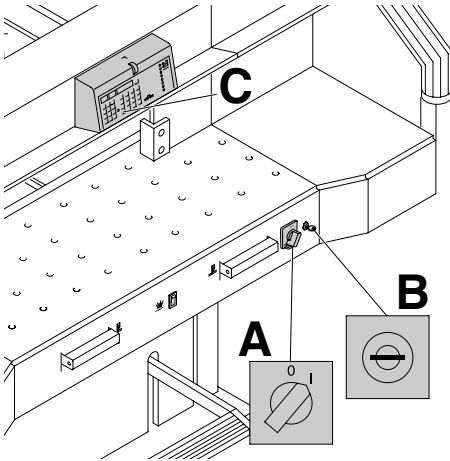

Position the main switch to "I" (A). Insert the key for the control system and turn it to the right (B).

Press  button (D) machine will automatically go to 72 cm or 28,346 inches.

The machine is now ready for use.

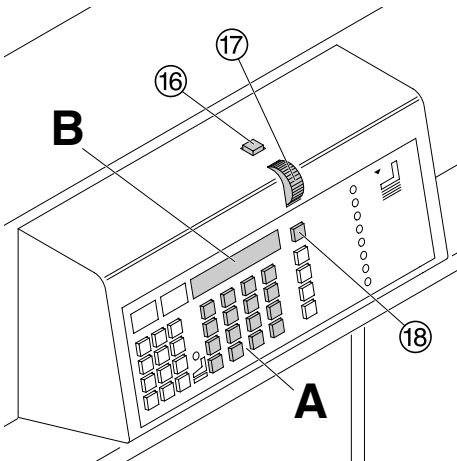

The measurement is set as follows:

- manually with the electric hand-wheel **(17)** or button **(16)** and **(18)**
- by programming the cutting dimensions **(A)**. Dimension is shown on the display in inches or cm **(B)**.

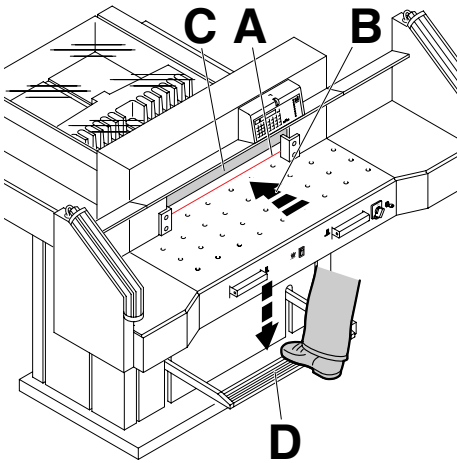

**Optical cutting line indicator:**

Optical cutting red line (A), indicates the position of the cut. Blade cuts on the front edge (B) of the light beam.

**Mechanical cutting line indicator:**

The clamp (C) can be used as cutting line indicator for cutting. Pre-clamping can be performed using the foot pedal (D).

Only use the optical cutting line indicator and mechanical cutting line indicator when no exact cut is required.

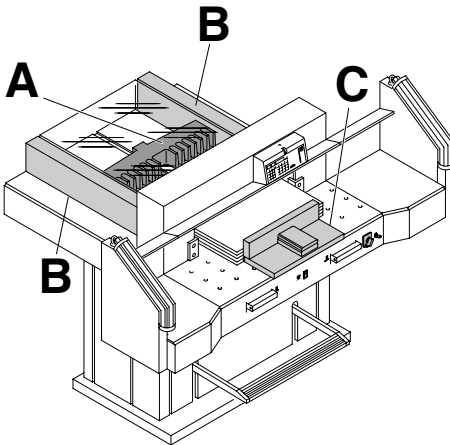

Position the paper on the backgauge (A) and side lays left or right (B).

To move paper stacks, please use the paper knock-up block (C) provided.

(Run backgauge to the front for turning the paper stack).

IDEAL 7260

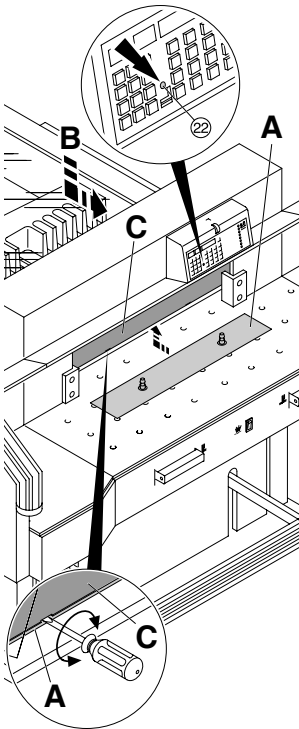

**False clamp plate:**

A clamp plate (A) is fitted to the machine to prevent pressure marks on sensitive material. LED ⑳ illuminates.

**To dismantle:**

- Remove the clamp plate (A) by turning the screwdriver (found in tool box) in the space between the clamp and clamp plate.
- Store the clamp plate in the provided holder (C) LED ⑳ deletes.
  - The remaining cut, without false clamp, is 20 mm

**⚠ Warning!**

**Make sure the false clamp is in the provided holder otherwise the measurement from 20 mm - 89 mm cannot be cut.**

**To mount:**

- The clamp plate (A) is inserted to the top into the clamp (D).
- The remaining cut, with false clamp, is 90 mm

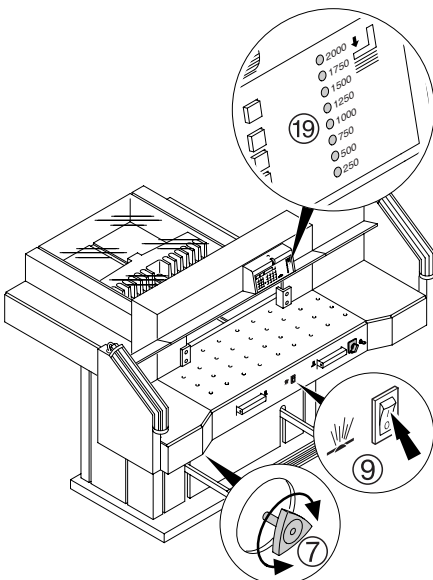

**Airtable:**

It is easier to position large stacks of paper when the airtable ⑨ is switched on.



**Setting clamping pressure:**

The clamping pressure can be adjusted using the adjustment knob ⑦. The clamping pressure can be read on the light panel ⑲.





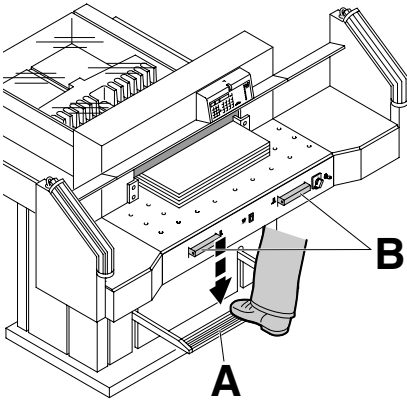

The clamp moves automatically when cutting is activated.  
The paper can be pressed in advance, with the foot pedal.  
Cutting is activated by pressing both actuators (A) on the front table.

### Symbols for cutting activation:

Cutting sequence with automatic clamping.

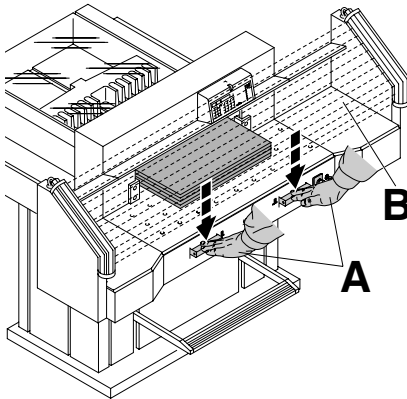

### Cutting activation:

Press both actuators of the two-handed control system (A) simultaneously and keep them pressed until the paper is completely cut.  
The safety area (B) must be free.

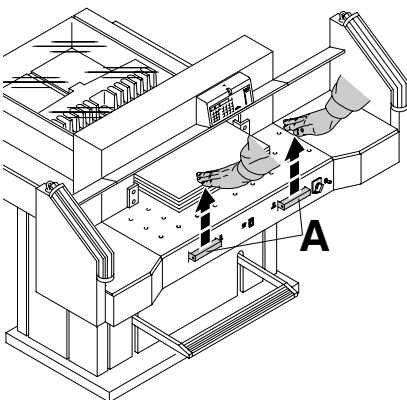

### To interrupt or stop cutting:

To interrupt or stop cutting, release both actuators (A) of the two-hand control.

IDEAL 7260

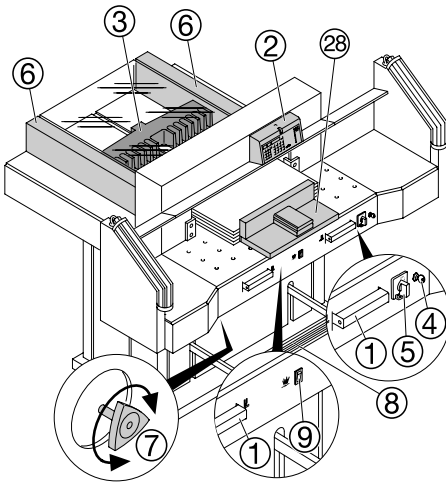

**Operating elements**

- ① - Safety two-handed control system pre-clamping and cutting
- ② - Backgauge control
- ③ - Backgauge
- ④ - Key switch
- ⑤ - Main switch
- ⑥ - Side lay left and right
- ⑦ - Clamp pressure adjustment
- ⑧ - Foot pedal
- ⑨ - Airtable switch
- ⑩ - Program number
- ⑪ - Program step
- ⑫ - LED "M" display memory
- ⑬ - LED "E" display eject
- ⑭ - LED "S" display error indication
- ⑮ - Display cutting size (cm or inch)
- ⑯ - Backgauge, backwards fast
- ⑰ - Electronical hand-wheel for fine adjustment
- ⑱ - Backgauge, forwards fast
- ⑲ - Clamp pressure
- ⑳ - Keypad
- ㉑ - Basic setting [F1], [F2], [F3], [E] (eject)
- ㉒ - Display false clamp plate
- ㉓ - Keypad with calculator
- ㉔ - Display impuls of backgauge movement
- ㉕ - Display in cm or inch
- ㉖ - Changeover cm-inch
- ㉗ - Calculating button
- ㉗ - Paper knock-up block
- ㉙ - USB connection port

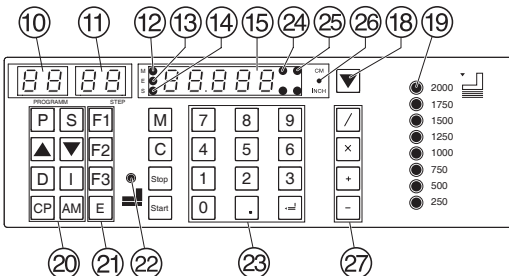
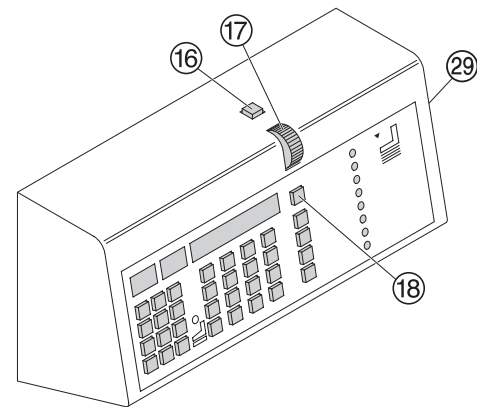

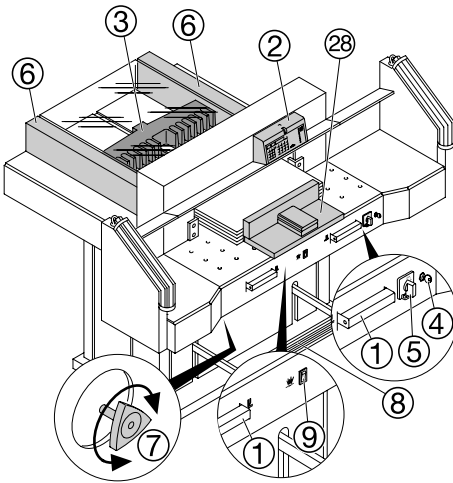

### Start machine

- Main switch (5) to position "I", insert the key (4) for the control panel and turn it to the right.
- Press **Start** button → backgauge (3) moves to the rear and searches for the reference position, wait until a measurement is shown in the display (15) (72 cm or 28,346 inches).

### ⚠ Warning!

Before storing or cutting a measurement please check if the correct measurement scale (72 cm or 28,346 inches) see above is stored. For information on how to store see bottom picture on page 24.

### Cutting to specified dimensions

- Enter dimension on the numerical key pad (23) → LED "S" (14) appears.
- Press **Start** button → dimension is approached, → LED "S" disappears.
- Insert paper and move by means of the paper knock-up block to the backgauge (9) and side lay on the left (10).
- Release the cut.

### Calculating

A measurement can be calculated with button (27). E.g. 20 - 2 **Start** and the backgauge advances immediately to 18.

### Cut according to markings

- Adjust the backgauge with button (16) to the back. (The backgauge will return quicker).
- Insert paper and move by means of the stacking angle to the backgauge (3) and side lay on the left (6).
- Turn the hand-wheel (17) to the front until the marking on the paper to be cut is under the cutting line indicator.
- The more the hand-wheel (17) is turned the faster, the backgauge will move. For fast mode use key (18).
- Release the cut.

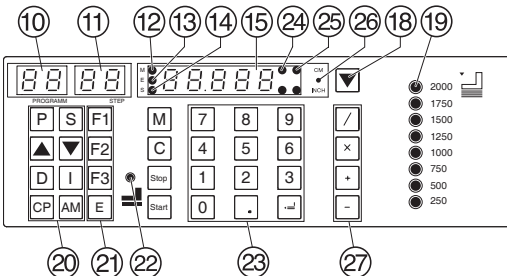
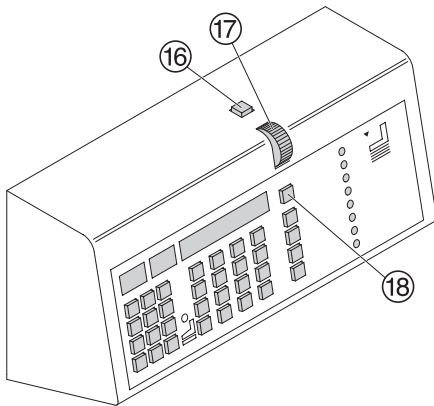

IDEAL 7260

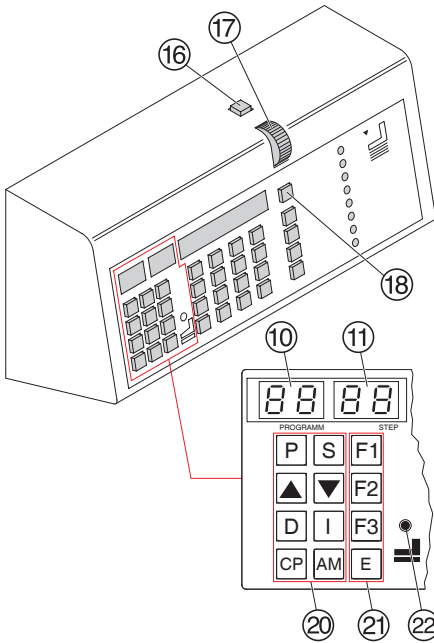

**Eject function**

If button **E** (21) is pressed the backgauge will advance to the preset measurement, ejecting the material to be cut, then automatically return to the position shown on the display.

**Adjust the eject-dimension**

- Press **P** and hold + press **E**  
→ **E<sub>J</sub>** on display.
- Insert the desired dimension.
- **=** Store dimension.

**Multiple cut**

- Enter the multiple cut size on the display (23).
- Advance to the measurement with the **Start** button.
- Push the paper to the backgauge (3).
- Release the cut.
- Press **AM** button → "A" on the display (11)
- Enter the multiple cut size.
- Press **Start** button → backgauge will advance by the multiple cut size.
- After cutting the backgauge will advance by the multiple cut size.
- Pressing the **Stop** button shows the actual size.

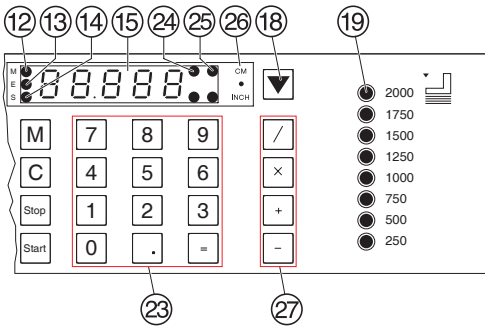

If, when inserting the multiple cut size, the **M** button is pressed instead of the **AM** the LED "M" (12) will light and after every cut the **Start** button must be pressed.

**Exiting program-mode**

- Press **M** button → LED "M" (12) is cleared on the display. The actual size is shown.

**Cutting activation**

**⚠ Warning!**

- Run backgauge to the front for turning the paper stack.
  - Do not interrupt the upward movement of the blade by performing switching procedures.
  - Release blade only when LED "S" (14) has gone out.
  - The safety area must be free.
  - Blade must always be at the top and be covered by the clamp. Do not touch the blade
- ⚠ risk of injury!**

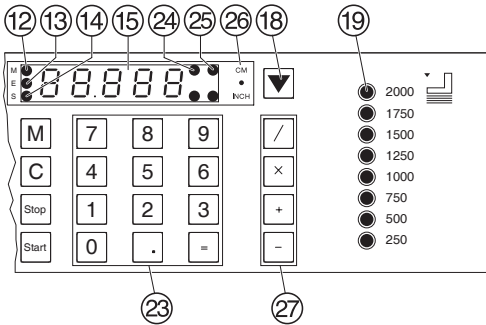
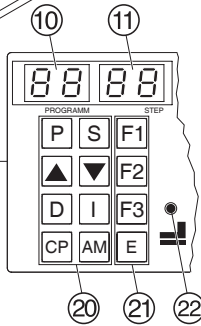
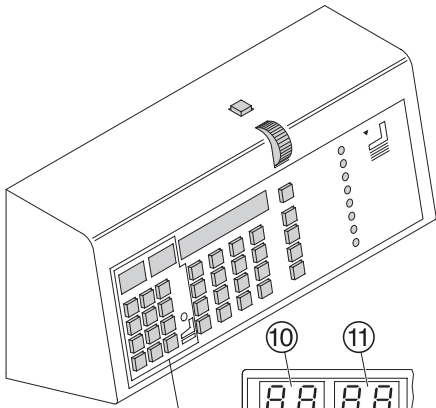

## Programming

This control system enables you to store 99 programs with 99 programmable steps. One step represents one measurement or max. 9 multiple cuts. After entering the program numbers you are able to change between several program steps with the button ▲ and ▼.

Program on display ⑩ = program number.  
Step on display ⑪ = program step.

The indicated program step can be overwritten at any time. These programs remain stored when the machine is off. Should you change to another dimension unit all programmed measurements are converted into the new unit (cm or inch).

## Operating elements

- P - Program number
- S - Program step
- M - Memory (multiple cut)
- AM - Memory (multiple cut with automatic control after the cut)
- ▲ - Program up
- ▼ - Program down
- C - Clear
- D - Delete
- I - Insert
- E - Eject
- CP - Clear Program
- Stop - Stop
- Start - Start
- cm inch - Display cm or inch

IDEAL 7260

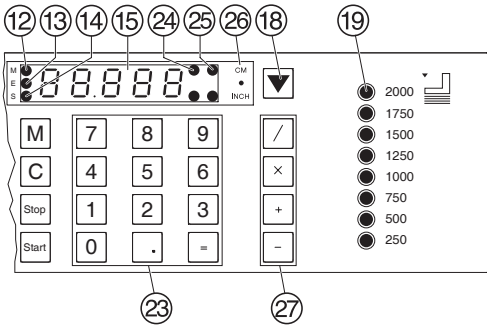
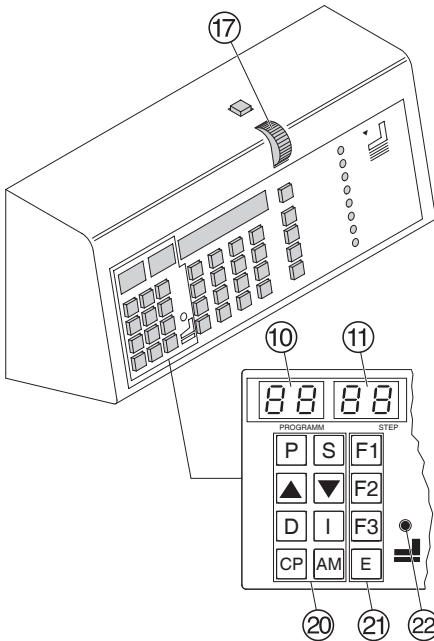

**Entering a program**

- Press **[P]** → *PR* appears on the display.
- Enter program number **[0][1] ... [9][9]**.  
The number will be shown on the display **(10)**
- If measurement is shown on the display **(15)** the program is reserved.
- Enter a measurement or advance with the hand-wheel **(17)**.
- **[=]** Store the dimension → next program step appears.
- Enter the next dimension.
- **[=]** Store the dimension
- **[P] + [Stop]** Escape the program mode.

**Eject function program**

- The eject function can be added each time a measurement is entered and ejects before advancing to the next measurement.
- Enter the next dimension.
- Press **[E]** → LED "E" appears.
- **[=]** Store the dimension.

**Example of a program eject function**

- **[P][0][8]** program 08
- **[CP][CP]** delete previous program
- **[2][7]** step 1 on 27,0 cm
- **[E][=]** eject
- **[1][9]** step 2 on 19,0 cm
- **[P][Stop]** escape the program mode

**How the example works**

- **[P][0][8]** start program 08
- **[Start]** proceeds to position
- Insert paper
- Release cut 1
- Release cut 2
- Paper is ejected
- **[P][Stop]** escape the program mode

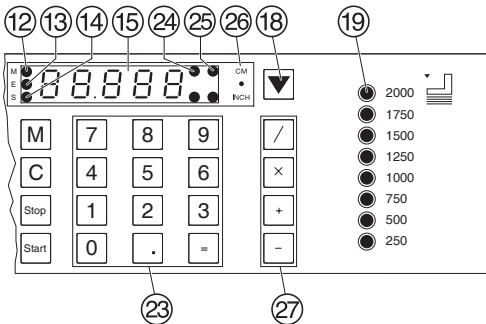
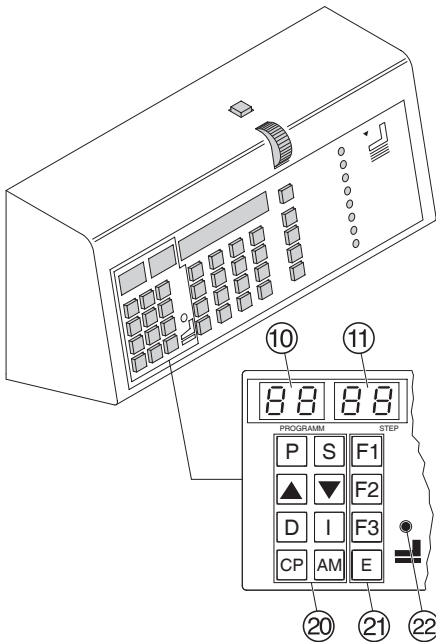

### Multiple cut program

- Press **AM** until the multiple cut size is reached ( $n \cdot l$ ,  $n \cdot c$  usw. max. 9 mal).
- Enter multiple cut size.
- **[ ]** Store the dimension.

### Example of a program with multiple cut

- **[P]** **[0]** **[9]** program 09
- **[CP]** **[CP]** delete previous program
- **[5]** **[0]** **[=]** step 1 on 50 cm
- **[AM]** first multiple cut size  $n \cdot l$
- **[AM]** second multiple cut size  $n \cdot c$
- **[2]** **[=]** e.g. multiple size 2 cm
- **[P]** **[Stop]** escape the program mode

### How the example works

- **[P]** **[0]** **[9]** start program 09
- **[Start]** proceeds to position 50 cm
- Insert paper
- Release cut 1 cuts multiple size 2 cm
- Release cut 2 cuts multiple size 2 cm
- Release cut 3 cuts multiple size 2 cm
- Backgauge proceeds to position 50 cm
- **[P]** **[Stop]** escape the program mode

### Changing select program

The **[S]** button is used to select a program step quickly and change a dimension.

- Press **[P]** → *PR* appears on the display.
- Enter desired program number **[0]** **[1]** ... **[9]** **[9]**.
- Press **[S]**.
- Enter program step to be changed **[0]** **[1]** ... **[9]** **[9]**
- Change dimension.
- **[=]** Store the dimension.

A program step can also be selected using the **[▲]** or **[▼]** button.

- Overwrite dimension.
- **[=]** Store the dimension.

### Insert a step

The inserted program step will appear before the step shown in the display.

- Choose a step number with button **[▲]** or **[▼]**
- Press button **[I]**.
- Enter dimension.
- **[=]** Store the dimension.

IDEAL 7260

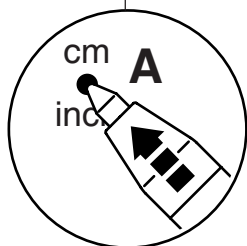
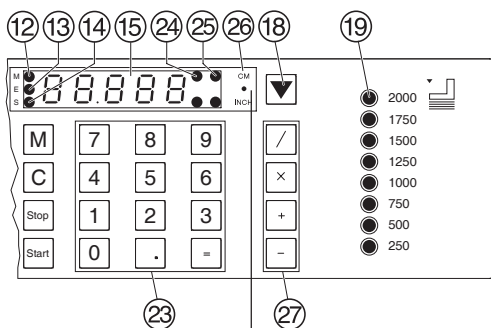
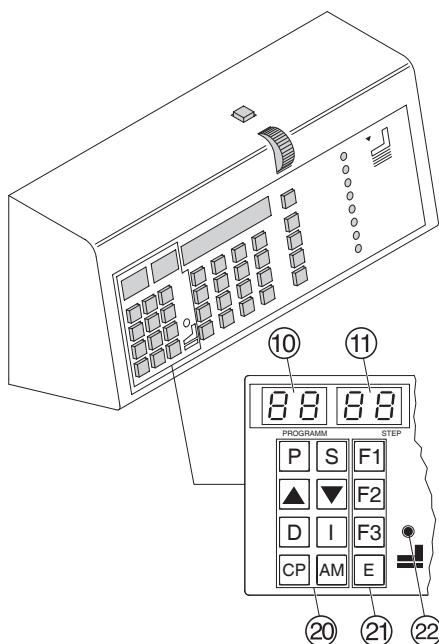

**Delete a step**

- Choose a step number with button ▲ or ▼
- Press button □ twice.

**Delete a program**

- Enter program number 0 1 ... 9 9.
- Press button □ twice.

**Changing the basic settings**

Frequently used dimensions are stored in the control system.

- F1 Basic setting 21 cm (8,267").
- F2 Basic setting 14,85 cm (5,846").
- F3 Basic setting 10,50 cm (4,133").
- E (Eject) Basic setting 20 cm (7,87").

Changing a basic setting:

- Press P and hold + press F1  
→ Setting blinks.
- Enter new setting.  
= Store the dimension.

**Basic settings**

**Display in cm or inch**

- Press  $\frac{cm}{inch}$  (A) → display changes between cm and inch. The corresponding LED light will be on.

**Display brightness**

- Press  $\frac{cm}{inch}$  and hold + press D.  
→ display changes between light and dark.

**Cutting counter**

- Press  $\frac{cm}{inch}$  and hold and press S.  
→ number of cuts are shown.  
Press D twice to delete the number of cuts.  
Press Stop to escape the cutting counter.



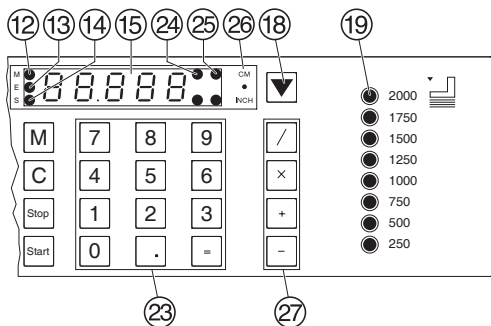
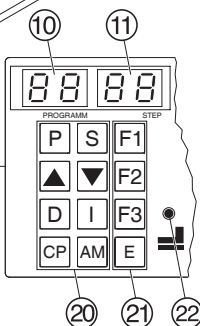
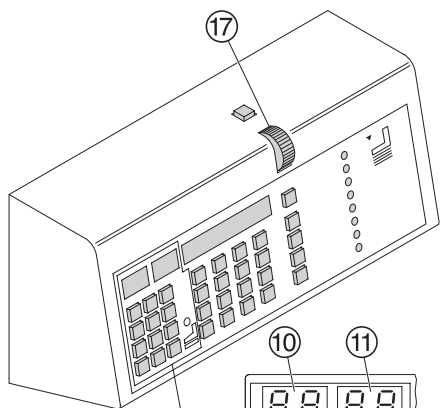

## Working with programs

- Press **P** → *PR* appears on the display.
- **0 1 ... 9 9** Enter program number.
- Press **Start** button → dimension is approached. Insert paper and move by means of the paper knock-up block **28** to the backgauge **9** and side lay on the left **10**.
- Release the cut → after every cut the backgauge advances to the next position. Release a cut see page 17.

## Correcting a measurement

When a dimension has to be corrected during cutting (e.g. program step 03) advance to the new cutting position with the rotary control **17** or enter the new dimension on the keypad **23**. **=** press, new measurement is stored. Press **Start** advances to the correct dimension. Cutting is activated and the correct measurement is cut.

**Attention: the correct dimension is now stored in the program**

With the button **↓** and **↑** you are able to change between several program steps. With **Start** the backgauge moves to the indicated dimension. With **Stop** the backgauge stops.

## General

LED "S" on → specified dimension not achieved.  
LED "S" is off → specified dimension achieved.

## Exiting program-mode

- Press **P** → *PR* appears on the display.
- Press **Stop** → Escape the program mode.

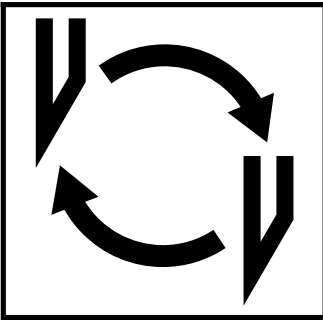

**If the cutting quality decreases:**

- Check the cutting depth (see page 34).
- Check the cutting stick (see page 30).
- Replace or grind the blade (see page 26 - 34).

**The blade cannot be ground if the blade height is less than 83 mm/3,29 inches. A new blade must be used.**

The blade may only be ground by a qualified supplier or from the manufacturer Krug & Priester, D-72336 Balingen.

**⚠ Danger! Risk of injury!**  
**The blade is extremely sharp. Do not extract the blade or transport it without the changing tool. Changing the blade may only be performed by trained staff.**

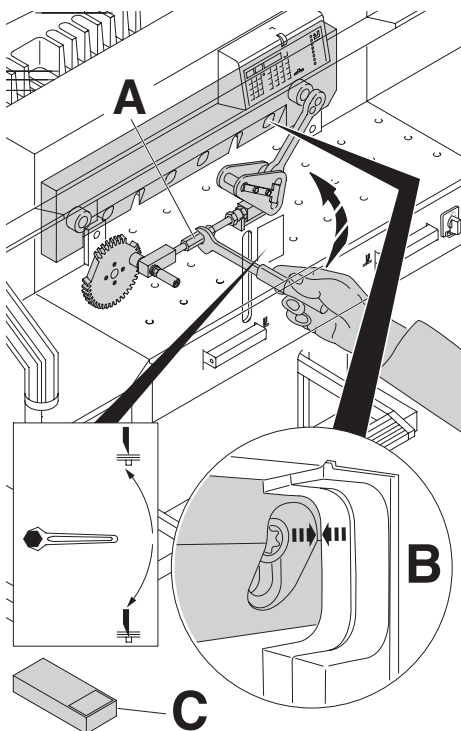

Turn the blade depth adjustment (A) towards the top until the blade screw recess corresponds with the frame recess (B). (Spanner found in tool set (C)).

Remove spanner

**⚠ Danger! Risk of injury**

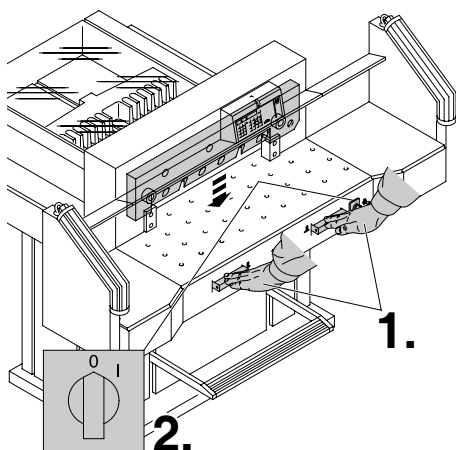

Lower the blade by pressing both cutting buttons (1.). Keep one button pressed and turn off the main switch (2.).

IDEAL 7260

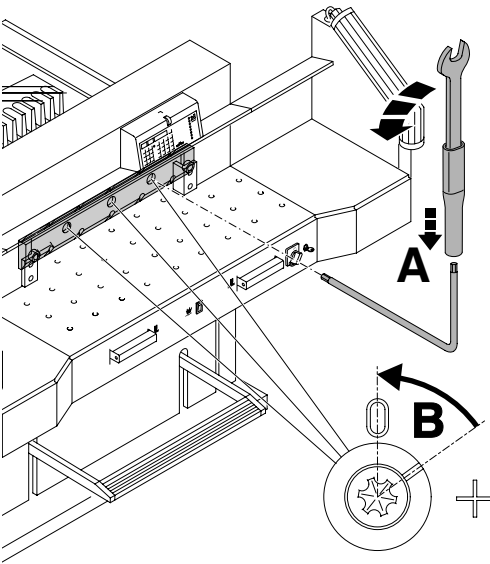

The 3 eccentrics are now exposed and should be turned counter clockwise to position "0" with the special wrench and attachable extension pipe (A) (in the tool set). The slot must correspond to position "0" (B).

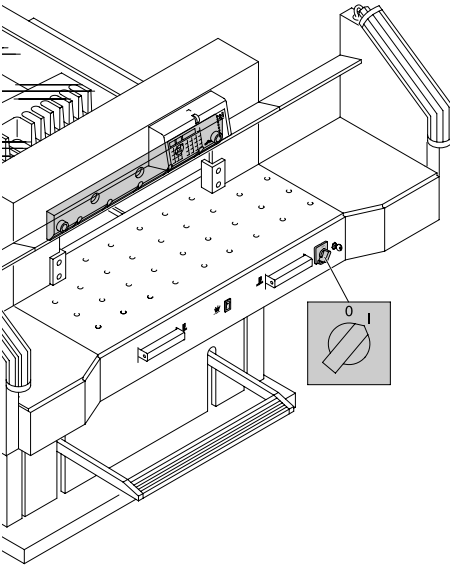

Remove the special wrench and turn on the main switch until the blade returns to the home position.

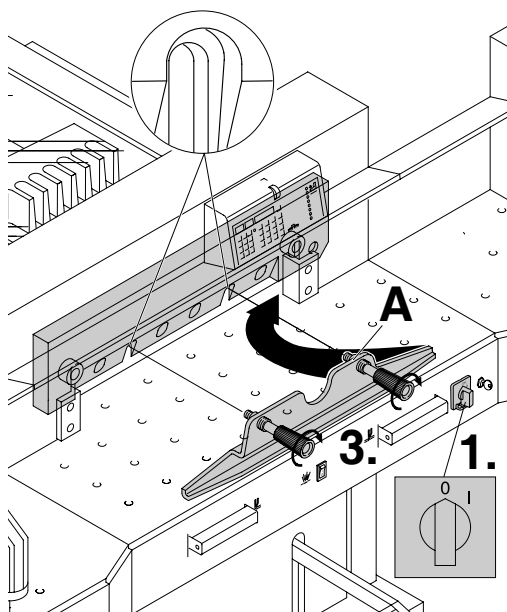

Position the main switch to "0" (1.)  
Remove the 2 blade screws on the elongated holes (2.). Then put the blade changing tool (A) into place and fasten it to the blade (3.).

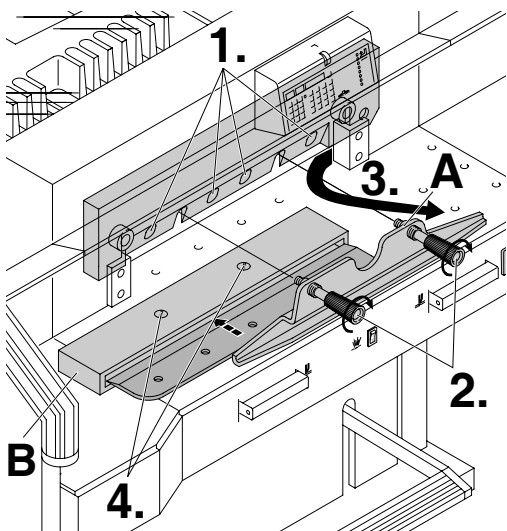

Remove 4 blade screws (1.)  
Loosen the grips (2.) of the blade changing tool (A) lightly and allow the blade to be taken downwards out of the machine (3.). Place the blade into the blade carrier (B) and screw it into place (4).

IDEAL 7260

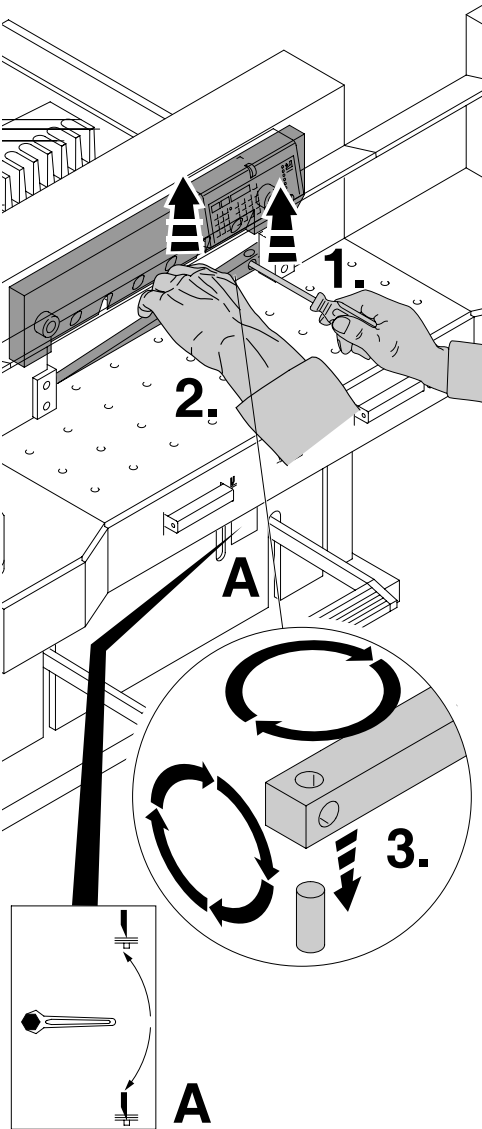

Take out the cutting stick with a small screwdriver. If needed the cutting stick can be turned or exchanged. (The cutting stick can be used eight times).

**Replacing the cutting stick (not the blade)**

- Turn the blade depth adjustment (A) towards the top until the blade screw recess corresponds with the frame recess. See page 27. (Otherwise the first cut will be too deep).
  - **Remove spanner**
  - Remove the cutting stick according to top picture.
  - Turn the cutting stick (the non-used side must be near to the blade) and plug it into the left holding bolt.
- ⚠ **Danger!** Risk of injury!

**Cutting test after replacing the cutting stick (not the blade)**

- Insert the paper and release the cut.
- If the last sheet of paper is not cut along the entire length turn the blade depth adjusting screw (A) 1/12 downwards using a spanner.
- If the last sheet is still not completely cut repeat this process until the last sheet is cut along the entire length.

• Blade and cutting stick replacement •

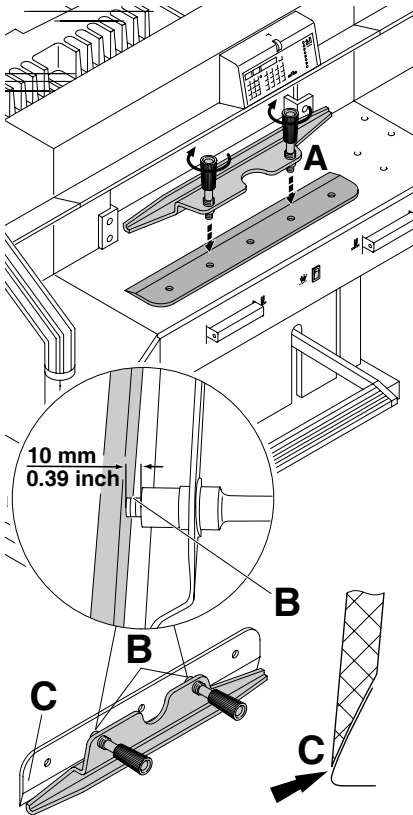

Take the exchange blade carefully out of the blade box and screw it to the blade changing tool (A)

- Make sure there is a space of 10 mm or 0.39 inches! (B).
  - Blade must be covered! (C).
- ⚠ **Danger!** Risk of injury!

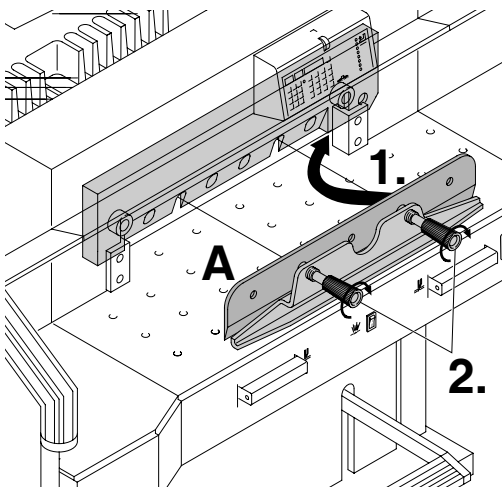

Place the blade to be exchanged with the blade changing tool (A) mounted (1.), into the blade carrier and push it up to the top and screw it into place with the grips (2.).

IDEAL 7260

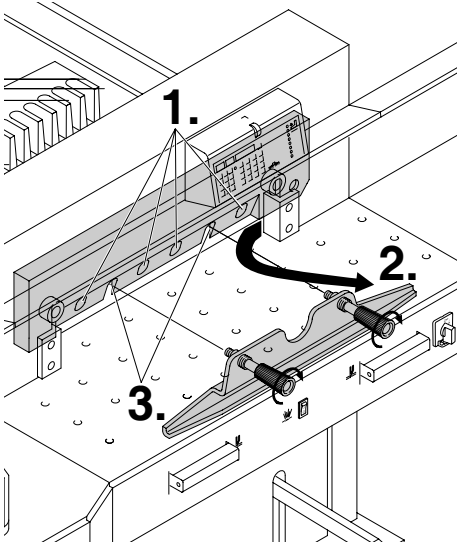

Lightly tighten 4 of the 6 blade screws with washers (1.). Remove the blade changing tool (A) (2.). Lightly tighten the remaining blade screws with washers (3.).

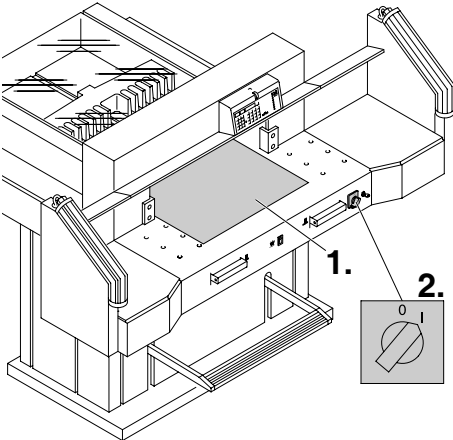

Remove all tools and distribute paper along the entire cutting length (1.). Turn main switch to position "I" (2.).



• Blade and cutting stick replacement •

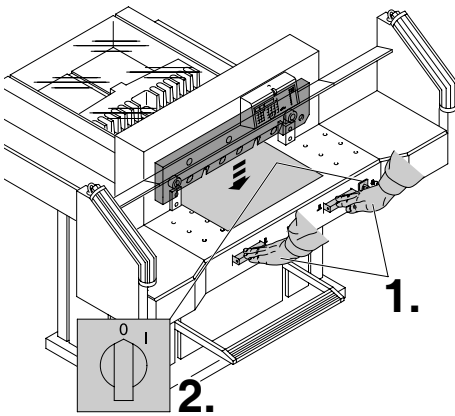

Lower the blade by pressing both cutting buttons (1.). Keep one button pressed and turn off the main switch (2.).

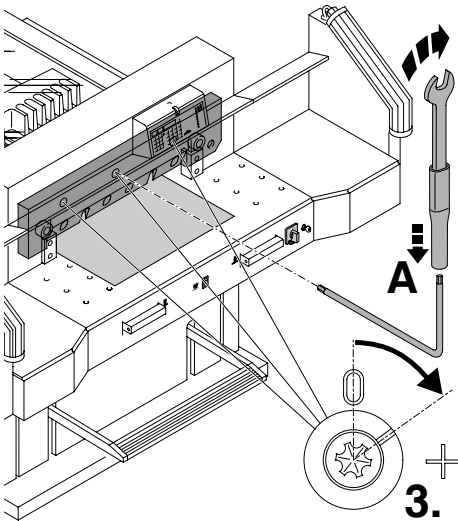

With the special wrench (A) the 3 eccentrics should be screwed down until the paper is cut along the entire length of the blade (3.) (The blade must remain parallel, not too deep into cutting stick).

IDEAL 7260

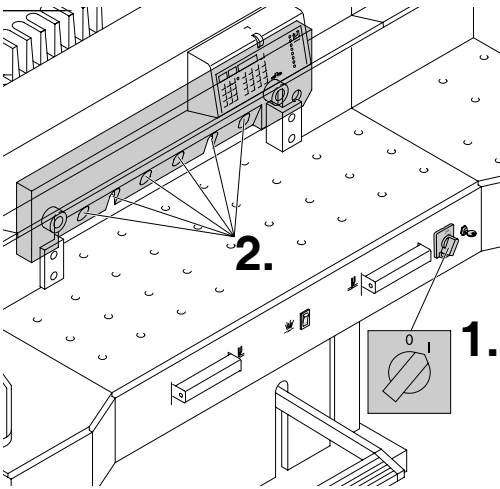

Turn main switch to position "I" (1.). Blade will return to upper position. Tighten 6 blade screws (2.) firmly.

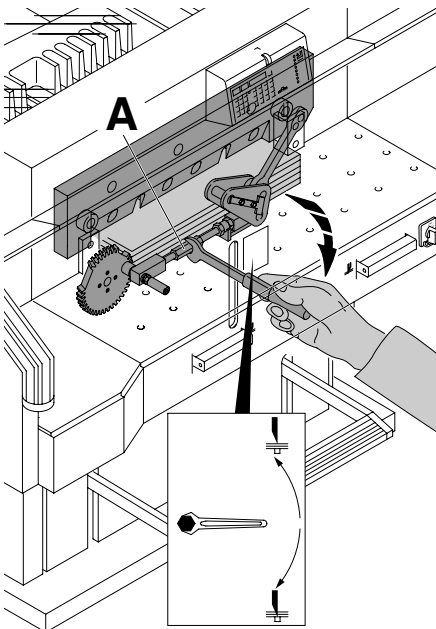

Paper cutting test. If the last sheet or several sheets are not completely cut, gradually turn the blade depth adjustment (A) 1/12 downwards until all the paper is completely cut. Do not set too low as blade will become blunt sooner.

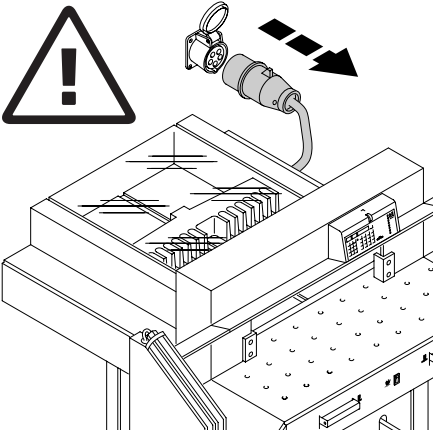

**⚠ Danger!**

- Maintenance work may only be performed by trained staff.
- Disconnect the mains before starting any service work or before removing the cover.

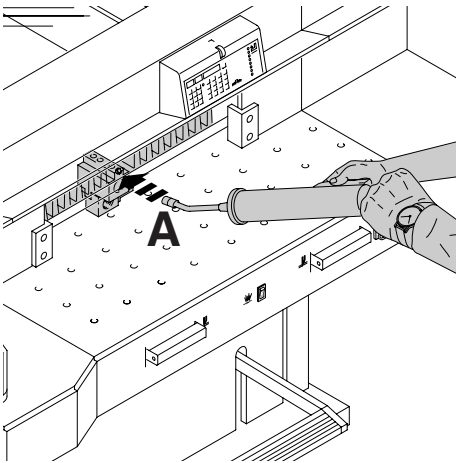

Grease the backgauge (A) control weekly with a grease gun. Advance the backgauge as far as possible to the front. (Use non-resinous oil or grease).

IDEAL 7260

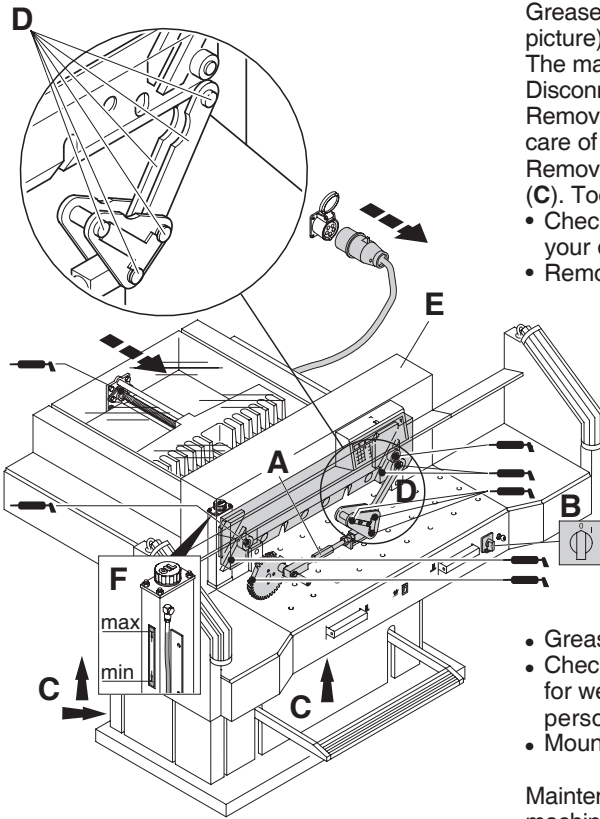

Grease the remaining parts twice a year (see picture).  
 The main switch must be on "0" (B).  
 Disconnect from the mains.  
 Remove the front upper housing (E) → taking care of the cable.  
 Remove lower panel and rear wooden panel (C). Tools in tool set.  
 • Check oil (F). If oil is below minimum contact your dealer.  
 • Remove any paper.

- Grease the machine.
- Check the 4 joining bolts and 2 pushing bars for wear (D). If necessary inform your service personnel.
- Mount the machine.

Maintenance work must be carried out on the machine every 5 hours.

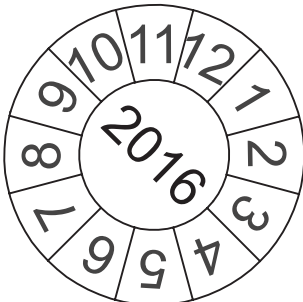

**Safety test**

The safety regulations are according to the regulations of the country where the cutting machine is operated. The manufacturer recommends a safety check is made every 5 years by an authorised service team.



**Machine does not function!**

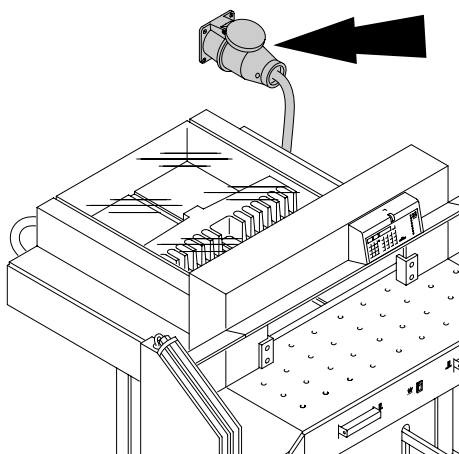

Is the machine plugged in?

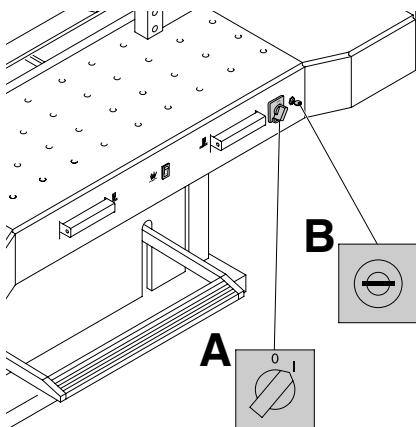

Main switch to position "I"? **(A)**  
Control system activated? **(B)**  
(Turn key to the right)  
Check the units fuse and the on-site circuit breaker!  
Release a cut see page 17.

IDEAL 7260

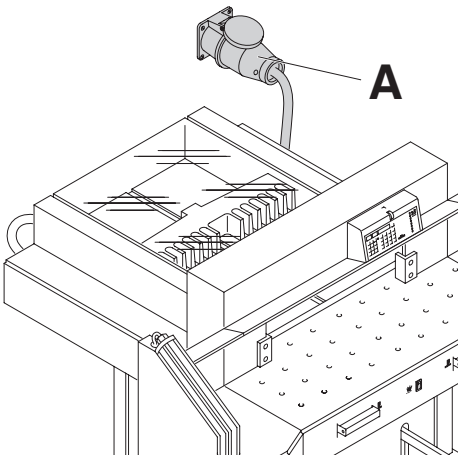

**The machine does not function after being moved to another position.**

If the machine still does not function then the rotation must be reversed. The machine is wired according to the IEC standards. We recommend that alterations to the rotary direction be made in the socket. It is also possible to make alterations in the plug by exchanging "L1" and "L2".

**⚠ Danger!**

Incorrect exchanging of the connections will endanger the operator. **This work must be carried out by an electrician.**

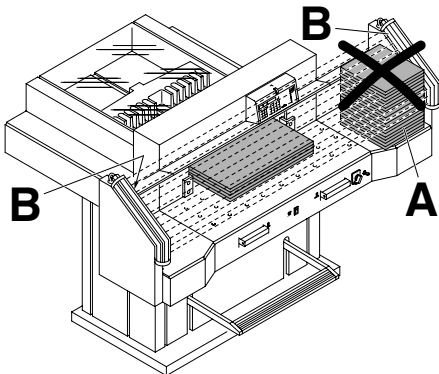

**Cut cannot be activated.**

- **Safety light beam is interrupted /dirty.**  
Remove all items obstructing the safety area (A) and clean the glass from the sender (B) and receiver (B).
- **Measurement has not been reached correctly.**  
→ LED "S" ⑭ does not turn off.  
Push the Start button again.
- **Measurement below 9 cm.**  
The false clamp plate must not be mounted. Remove the false clamp plate and store it in the provided holder (see page 16).

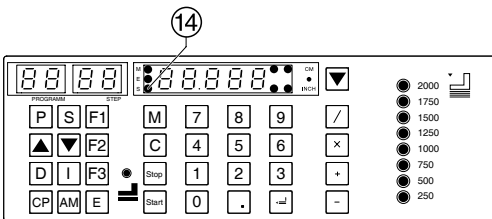

• Possible malfunctions •

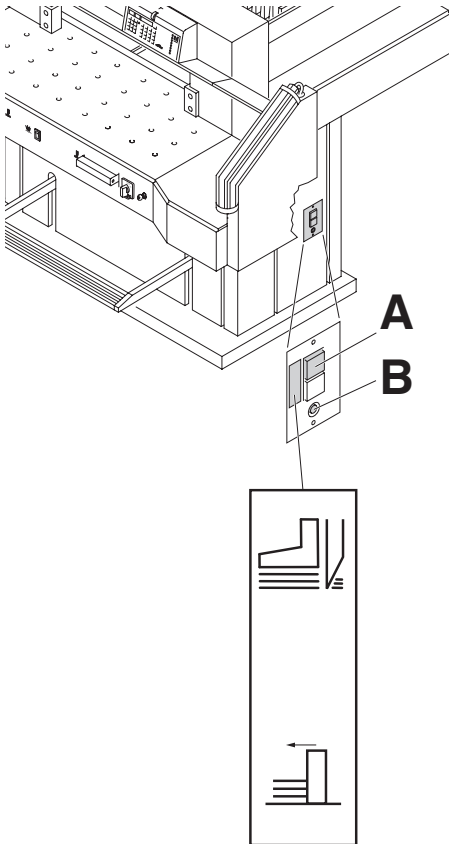

**Machine turns off:**

- **Machine overloaded.**  
Safety button (A) ejects.  
Reset the safety button (A).
- **Machine blocked.**
- **Blade is blunt.**  
Eliminate the cause, and push the safety button (A).
- **Backgauge blocked**  
Safety button (B) ejects.  
Eliminate the cause, and push the safety button (B).

**Safety button for:**

**A = Blade drive**

**B = Backgauge drive**

IDEAL 7260

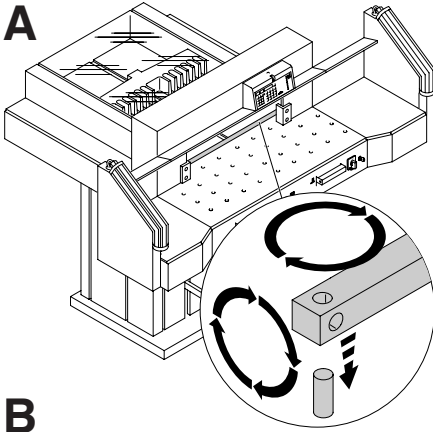

**Does not cut through the last sheet:**

- Turn or turn around the cutting stick (**A**), readjust the blade by means of blade depth adjustment (**B**) (see page 34).

**Poor cutting quality or blade stays in the paper stack.**

- Change the blade (**C**) (see pages 26 - 34).

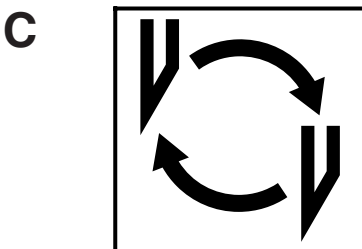
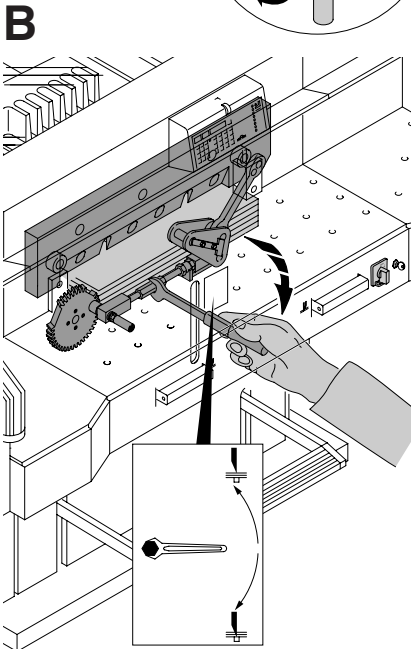



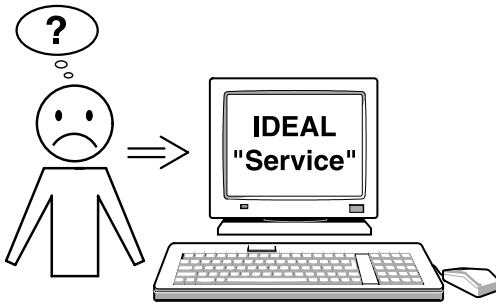

**Motor runs but blade does not move downwards.**

- Security brake has been activated!  
Inform the Service Team!
- [www.ideal.de](http://www.ideal.de) → "Service"  
[service@krug-priester.com](mailto:service@krug-priester.com)

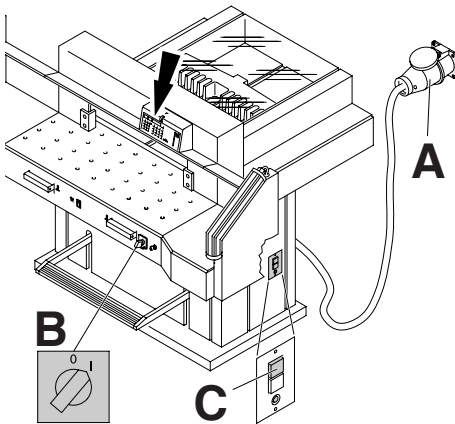

**Display illumination off**

- Is the machine plugged in? (A)
- Is the main switch on position "I"? (B)
- Push in the green safety button! (C)
- Check the units fuse and the on-site circuit breaker!

IDEAL 7260

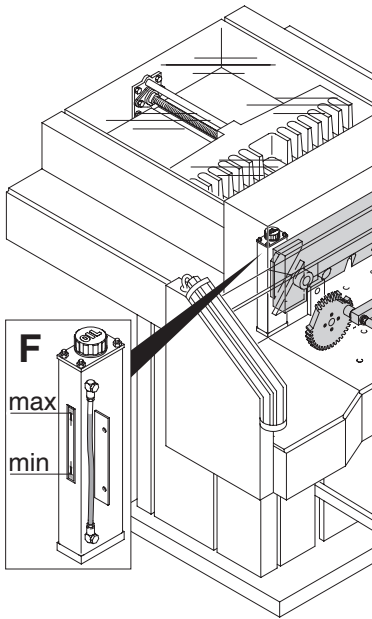

**No clamp pressure.**

- Hydraulic oil needs refilling.
- Contact your dealer.**

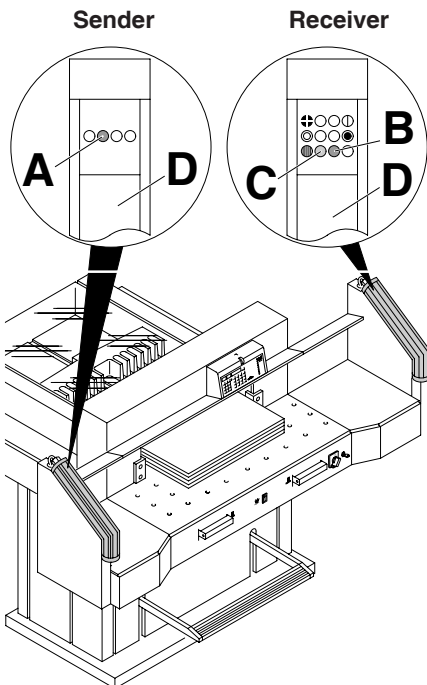

**Trouble shooting-light beam**

- During normal operation the LED (A) must illuminate orange and LED (B) green.
  - Display (C) is permanently on orange when the sender and/or receiver require cleaning.
- Clean the glass (D) from the sender and receiver.**

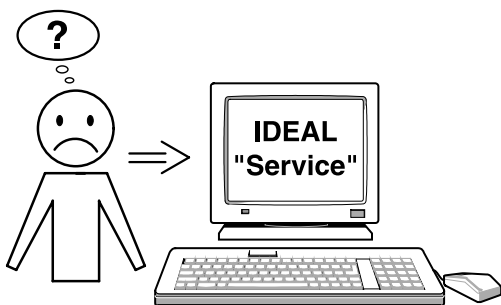

**None of the above mentioned methods helped to solve the problem:**

Contact Service Team under

- [www.ideal.de](http://www.ideal.de) → "Service"  
service@krug-priester.com

IDEAL 7260

**Recommended accessories:**

**HSS - Blade**

- Nr. 9000 141

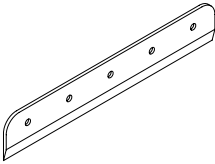

**Cutting stick (6 pieces)**

- Nr. 9000 039

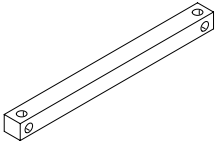

**Blade changing tool <sup>1</sup>**

- Nr. 9000 514

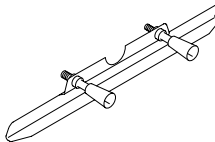

**Paper knock-up block <sup>1</sup>**

- Nr. 9000 521

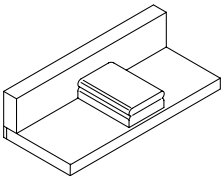

**Grease gun <sup>1</sup>**

- Nr. 9004 683

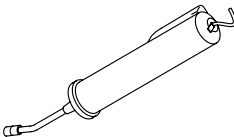

**Side tables left and right**

- Nr. 9000 550

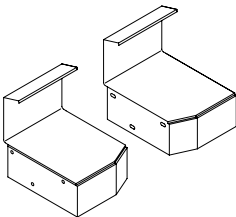

**USB - Connection cable**

- Nr. 9000 557

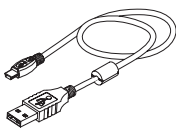

**CD - Software "Visioncut"**

- Nr. 9000 558



<sup>1</sup> Included in delivery

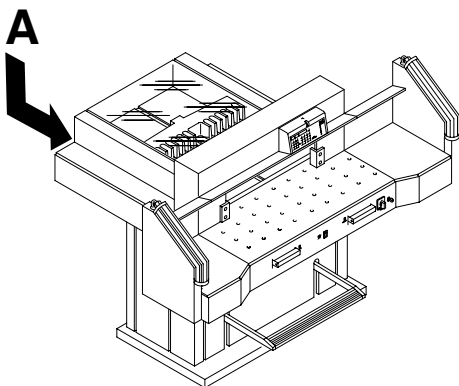

### Technical data:

- Power supply: 400V/50Hz/3~, 220V/60Hz/3~
- Cutting length: 720 mm
- Cutting height: 80 mm
- Table depth: 720 mm
- Sound level EN 13023: 72 dB (A)
- Minimum space requirement (width x depth x height) 1305/2100<sup>1</sup>mm x 1500/1600<sup>1</sup>mm x 1355 mm
- Leakage current < 3,5mA
- Power cord gauge min. 1,5mm<sup>2</sup> (400V)
- Power cord gauge AWG 14 (20A) (220V)
- Clamping pressure: min. 250 daN, max 2000 daN
- Weight: 613 kg, 620 kg<sup>1</sup>
- Capacity of hydraulic oil: 1,5 l HLPD, viscosity 46 mm<sup>2</sup>/ sec. to DIN 51562. Used oil must be disposed of at the authorised place.

<sup>1</sup> with side tables

The exact technical specifications can be found on the technical specifications sticker (A) on the machine. A wiring diagram is found in the electrical switch box.

To claim under guarantee, the machine must still carry its original identification label.

### Safety light beam

- Total reaction time: 101 ms
- Resolution 14 mm/minimum distance: 370 mm
- Resolution 30 mm/minimum distance: 480 mm
- Resolution 40 mm/minimum distance: 468 mm

Ambient operating temperature 10 °C - 60 °C  
Air humidity (not condensing) 15 % - 95 %

Krug + Priester has a certified quality management system according to DIN EN ISO 9001:2008 and a certified environmental management system according to DIN ISO 14001:2009.



IDEAL 7260

---



This machine is approved by independent safety laboratories and is in compliance with the EC-regulations 2006/42/EG and 2004/108/EG.

**Sound level information:**

The sound level is 72 db (A) as defined by EN 13023.

Subject to alteration without notice.



I.T.E. Listed 802 D

**D EG-KONFORMITÄTSERKLÄRUNG**  
**GB EC-declaration of conformity**  
**F Déclaration de conformité CE**

- Hiermit erklären wir, daß die Bauart von
- Herewith we declare that
- Par la présente, nous déclarons que

<b>7260</b>	<b>GS- IDENT. Nr.</b> <b>11072101</b>	<b>UL- IDENT. Nr.</b> <b>10072101</b>
-------------	--	--

- folgenden einschlägigen Bestimmungen entspricht
- complies with the following provisions applying to it
- sont conformes aux dispositions pertinentes suivantes

**2006/42/EG:**

Maschinenrichtline, EC Machinery directive, EC Directives machines.

**2004/108/EG:**

EMV Richtline, EMV Electromagnetic compatibility directive,  
EMV directives compatibilité électromagnétique.

- Angewendete harmonisierte Normen insbesondere
- Applied harmonised standards in particular
- Normes harmonisées utilisées, notamment

**EN 60204-1; EN 1010-1; EN 1010-3;**  
**EN 55014-1; EN 55014-2; EN 61496-1; EN 61496-2;**  
**EN ISO 12100; EN ISO 13857; EN ISO 13849-1; EN 13023;**  
**EN ISO 11204.**

29.12.2009  
Datum

Bevollmächtigter für technische Dokumentation  
Authorized representative for technical documentation  
Représentant autorisé pour la documentation technique



- Geschäftsführer-

Krug & Priester GmbH u. Co KG  
Simon-Schweitzer-Str. 34  
D-72336 Balingen (Germany)

• Document Shredders •



• Trimmers and Guillotines •

